

Universal 23, 13, 6 and 3 cm ATV transmitter controller V1.3

PE1MTH, T. Gosselink jr. , December 2000



Description

This circuit is meant to be able to set the transmitter frequency as accurate as possible, with a great freedom of frequency choose.

The frequency areas being covered are: 23 cm, 13 cm 6 cm and 3 cm. You can also set other frequencies as well. The maximum amount of frequency bands are 5. It's therefore possible to add 1,5 cm or an other band as well.

The theoretical tuning range runs from 0 to 4200 GHz as where 0 to 100 GHz will be displayed correctly.

Possibilities (Software version 1.3)

- The frequency can be tuned in steps of 250 KHz just by pressing the Up or Down keys. By keeping one of the keys pressed, de tuning will take please in increasing steps. (after 3 seconds, 2 MHz en after about 6 seconds, 10 MHz.)
- The system uses four memory banks of 10 channels each. The first is being used for 23 cm, the second for 13 cm, the third for 6 cm and the fourth for 3 cm (10 GHz).
- The chosen memory channel will be stored per band.
- By keeping the "mode" key pressed, the VFO frequency will be placed in the memory bank, pointed to by the memory channel value and visa versa.
- Installed as an convenient setup mode, which is accessible by keeping the "band" key pressed while powering up the system. By this methode, 10 GHz

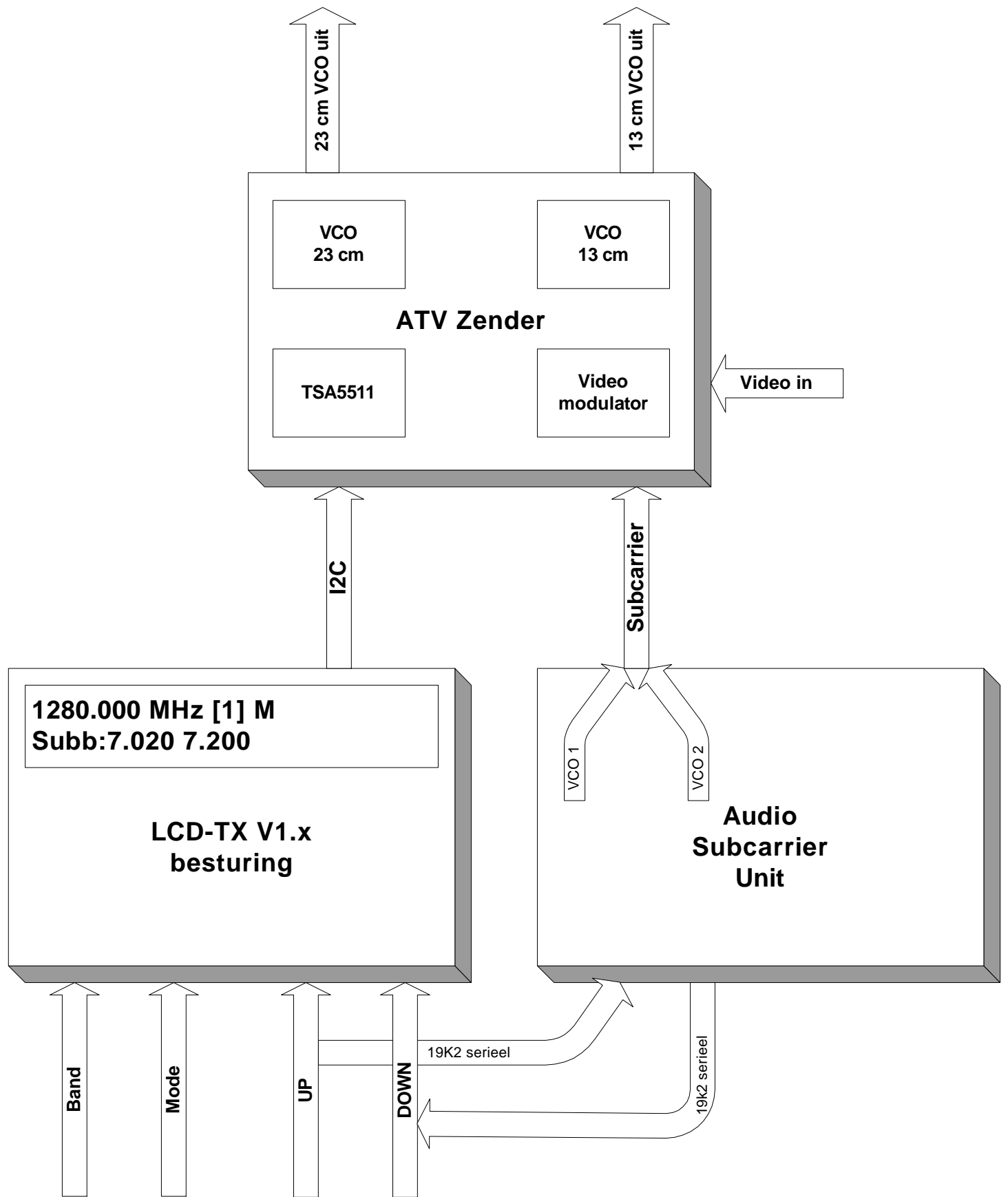

LCD TX
 Universele ATV zender
 PE1MTH & PE1AOE
 (c) 2000

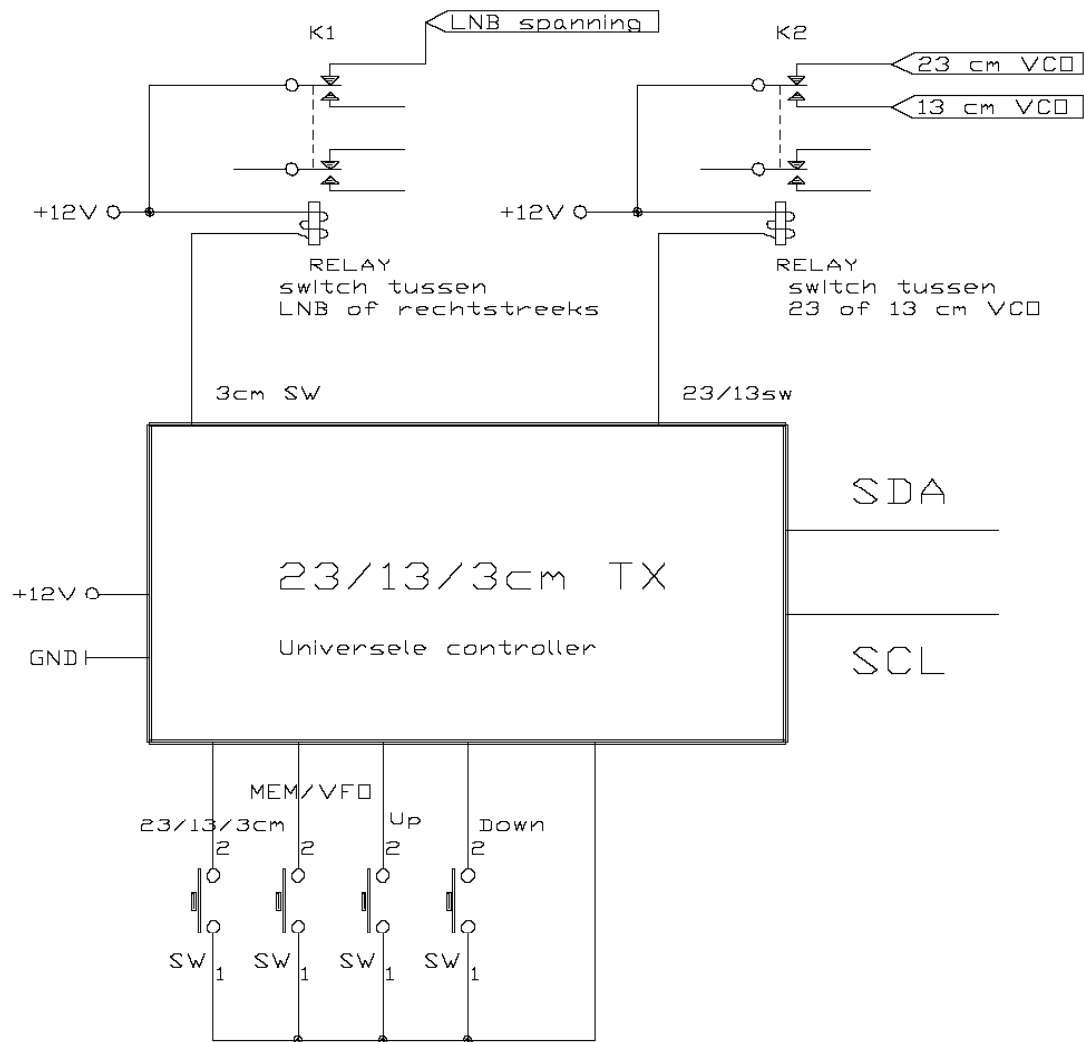

Title		
PE1MTH 11/1999		
Size	Document Number	REV
A	23/13/3cm TX	1
Date:	October 15, 2000	Sheet 1 of 1

band offset can be easily set, including the ability to enable band limits and other settings.

- This software is able to use another project, namely a stereo sub carrier generator which is PLL controlled and can be tuned freely, in mono (1 carrier) and in stereo (2 carriers). By connecting the up and down keys to this audio module, communication takes place automatically, and the audio carriers will be shown on the LCD display.

Construction

This controller used an advanced and small micro controller, the ATMEL 89C4051. Also used is an EEPROM memory chip to store all settings and frequencies. The micro controller drives the LCD display directly (2 lines, 16 characters). It also controls an external synthesizer (TSA5511 or the SP5055). Also added are two switch transistors to be able to switch between 23, 13 and 3 cm. 6 cm, will be switched from the external synthesizer.

Software

The software boots up with:

```
Multiband TX1.3  
29112000
```

After that, the last chosen settings appear on the display like mode, band and frequency.

Example 1:

```
1.281.000 [0] M  
Subb:7.020 7.200
```

This shows the following:

- The chosen transmit frequency is: 1,281 MHz
- The memory channel is 0 ([0])
- The system is currently in memory mode (M)
- Two sub carriers are being transmitted. (Stereo)

Example 2:

```
2.107.750 [5] F  
Subb:6.000
```

This shows the following:

- The chosen frequency is: 2,107.750 MHz

- The memory channel is 5 ([5])
- Currently the system runs in VFO mode, free tuning (F)
- Only one sub carrier is being transmitted (1 carrier)

Example 3:

10.425.000 [2] M

This shows the following:

- The chosen frequency is: 10,425 MHz
- The memory channel is 2 ([2])
- Currently the system runs in memory mode (M)
- The system did not detect a sub carrier board.

3 cm offset correction

The 3 cm mode, is nothing else then 23 cm, added with an offset. This offset is being set from within the setup menu and can be chosen freely.

Keep the “mode” key pressed while switching to controller on.

-Offset tuning

This is the place to set de offset frequency.

-Bandlimits

This controls if band limits should be attended. It can make sure, that you can not tune outside the valid amateur frequency range.

-10GHz Mode

This lets you chose between offset mode or the multiply mode (VCO * 8)

-Synth type

Chose of the TSA5511 and the SP5055.

-Exit

Exit setup.

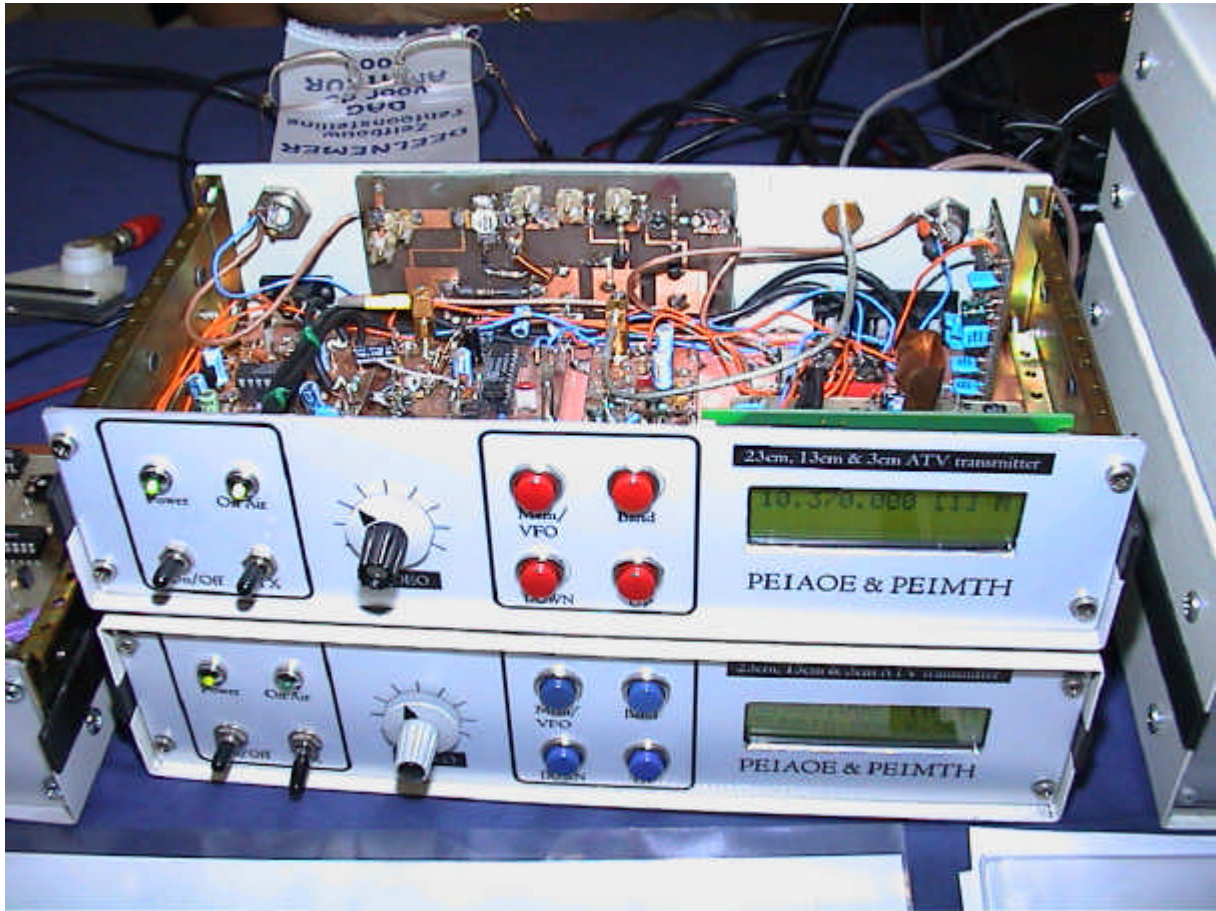

This picture shows version 1.2. This one didn't feature the 6 cm band.

Hardware